



FACE DRILL RIG WD581

Mining one-boom face drill rig for medium sized underground drifts, with maximum coverage area 35m².

With quality as the foundation and innovation as the driving force, Uniroc creates greater value for you.

unirocgroup.com



Reliable and durable rig



Most reliable U1838ME rock drill

FOPS&ROPS approved telescopic protective roof

Self-diagnostic and voice alarm system

Robust boom for efficient and trouble-free operation

Strong and stable carrier with imported environmental friendly Chinese IV stage engine

Main features:

1# Easy:

Adopting electro-proportional hydraulic control makes drilling and positioning more convenient, flexible and precise.

2# Automatic:

With automatic drilling, automatic retraction, automatic jamming release, automatic stopping impact and other functions.

3# Digital:

Digitally record the number of holes drilled, drilling depth and other data, real-time supervision and evaluation of the construction situation.

4# Safety:

Equipped with self-diagnosis and safety voice alarm system, real-time monitoring and fault detection.

Face Drill Rig WD581

A Partner Worthy Of Your Trust

Uniroc U1838ME Rock Drill

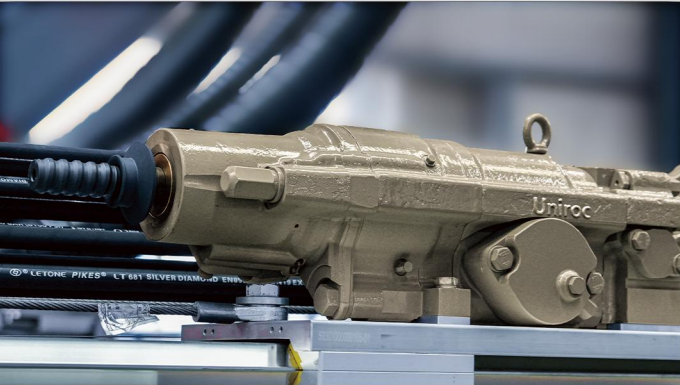

Our self-developed rock drill U1838ME is specially equipped with a secondary buffer system, which greatly extends the service life of the hydraulic rock drill. It is also equipped with advanced frequency conversion system at all levels, which enables it to flexibly cope with a wide range of different levels of surrounding rock conditions, completely solving the limitation of traditional rock drills that are difficult to be used for multiple purposes.

Operator Station



Excellent visibility, logical operating layout, and high illumination LED working lights & tramming lights ensure improved productivity and safe operation.

Drilling System



Adopting high efficient and fast electro-proportional hydraulic control drilling system, including automatic drilling, automatic retraction, automatic release of jamming brazier and other functions.

Professional service offering



Uniroc's service solutions ensure that your equipment performs at its best throughout its life cycle.

By combining genuine parts and Uniroc services from our certified technicians, we provide the highest quality technical support to ensure that your equipment continues to run efficiently and safely.

Measurements

Side View

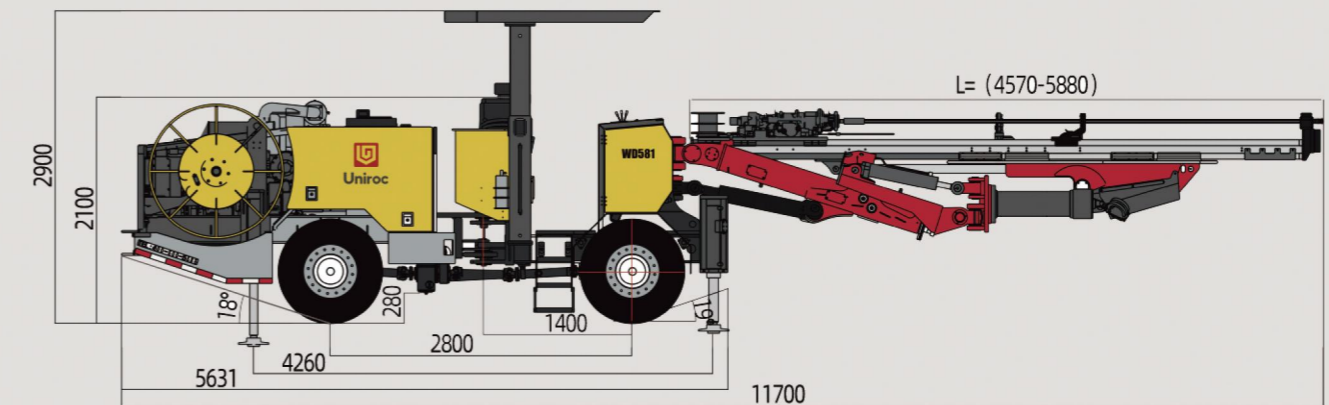

Coverage Area

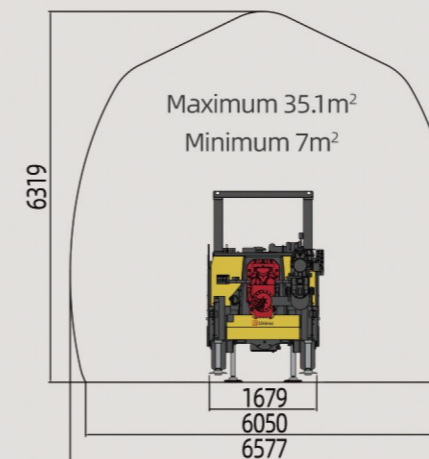

Turning Radius

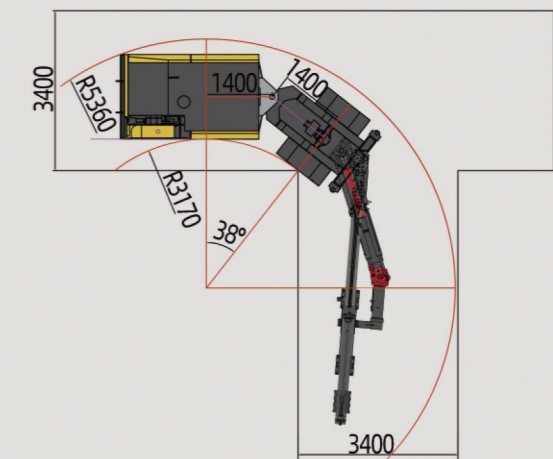

Dimensions		
mm	Width	1800
	Height roof up/down	2100/2900
	Length with BMH A feed	11700
	Ground clearance	260
Weight		
Gross weight, depending on configuration		
Kg	Total	13600
	Boom side	3200
	Engine side	10400
Tramming speed		
km/h	On flat ground (rolling resistance 0.05)	>10

Face Drill Rig WD581

Technical Specifications

Rock drill	
Shank adapter	T38
Height over drill centre	88mm
Length without shank	1008mm
Impact power	18kW
Impact rate	60Hz
Rotation system	Separate rotation
Rotation speed	0-215rpm
Rotation torque, max	1000Nm
Lub.air consump.at 2 bar	5L/s
Water consumption	40-120L/min
Sound level	<106dB(A)

Electrical system	
Total installed power	65kW
Main motor	1x55kW
Voltage	380-660V
Frequency	50-60Hz
Starting method	star/delta
Transformer	0.3kVA(660V/6kVA)
Cables reel	660/1095mm
Thermal overload protection for electric motors	
Percussion hour meters	
Digital voltmeter/amperage meter in display	
Phase sequence indicator	
Battery charger	

Air system	
Capacity max. at 7 bar	6.8 L/s
Air pressure gauge	

Control system	
Electro-proportional hydraulic control system	
Basic functions such as anti-jamming included	

Feed			
	Model A Standard	Model B Optional	Model C Optional
Total length	5873mm	5262mm	4658mm
Drill rod length	4305mm	3700mm	3090mm
Hole depth	4000mm	3400mm	2800mm
Weight, incl. drill	640kg	610kg	570kg
Feed force	7-15kN	7-15kN	7-15kN

Carrier	
Power rating at 2200 rpm	66kW (90 hp)
Torque at 1300 rpm	360Nm
Articulated steering	38° steering angle
Rear axle	±7° oscillation
Tyres	8.25-20
Hydraulic jacks, front	2 extendable
Hydraulic jacks, rear	2
Service brakes	2 separate circuits
Emergency and parking brakes	Spring brake
Fuel tank, volume	85L
Electric system	24V
Batteries	2x12V, 120Ah
Driving lights	LED 2x100W & 2x30W 24V DC
Work lights	LED 6x30W, 24V DC
Gradeability at max load on drive wheels	15°
Water-cooled diesel engine, Chinese Stage IV	
Fixed seat for tramming	
Four-wheel drive	
Hydrostatic transmission	
Automatic differential	
Silencer	
Fier extinguisher	
Spirit level	
Horn, beacon and reverse alarm	

Boom	
Feed extension	1500 mm
Boom extension	1250 mm
Parallel holding	complete
Feed roll-over	360°
Lifting angle	+65°/-30°
Boom swing angle L/R	±35°
Weight, Boom only	1750 kg

Hydraulic system	
Hydraulic pumps	1 unit
System pressure, max	230bar
Hydraulic oil tank, volume max	240L
Filtration	10um
Pumps unloaded at start	
Oil filter indicator	
Low oil level indicator	
Water cooled oil	
Mineral hydraulic oil	

Water system	
Water booster pump working capacity, L/min	0.7-2.4
Water booster pump working pressure, bar	25
Min. water intet pressure, bar	2
Water flow guard	

Optional equipment

Drifter rods		
Dimension		Min. hole diameter
mm	R32-H35-R38	45
	R32-H35-T38	45
	R32-H35-T38 Speedrod	45
	R32-D39-T38	45
	R32-D39-T38 Speedrod	45

Couplings			
Thread		Diameter	Length
mm	R38	55	170
	T38	58	190

Rock drill	
Big hole drilling kit	

Feed	
Telescopic feed	

Face Drill Rig WD581